

PK 78002-SH

High Performance

PALFINGER CRANE

CQ – 593 – BZ

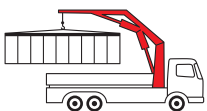

KTL
protected

**Paltronic
150**
controlled

RRC
Radio Remote Control
operated

HPSC
High Performance Stability Control
monitored

AOS^{*)}
Active Oscillation Suppression
inside

DPS^{*)}
Dual Power System
activated

Best in class for versatile heavy-duty jobs

Uncompromising quality down to the last detail, an unbeatable power to weight ratio and its intelligent control concept make the PK 78002 SH second to none in the 80 meter tonne class.

Be it moving heavy machinery in halls, precision installation assignments or delicate loading of boats – as a multi-talented quick-change artist, the PK 78002 SH always pulls out the right stops for every task.

Concentrated PALFINGER crane technology

PK 78002 SH High Performance

G

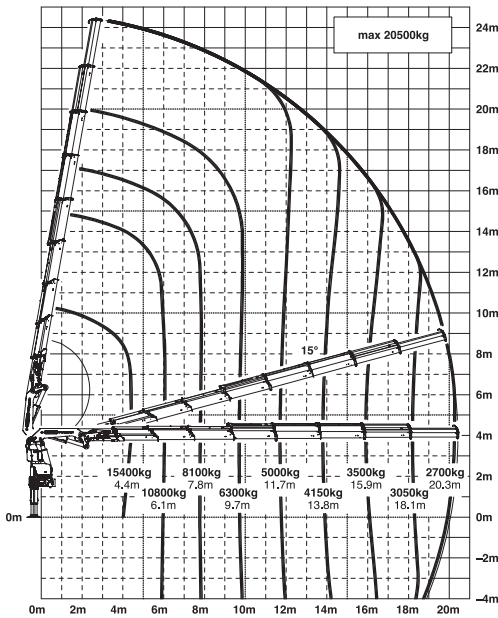

E PJ170E JV1 DPS PLUS

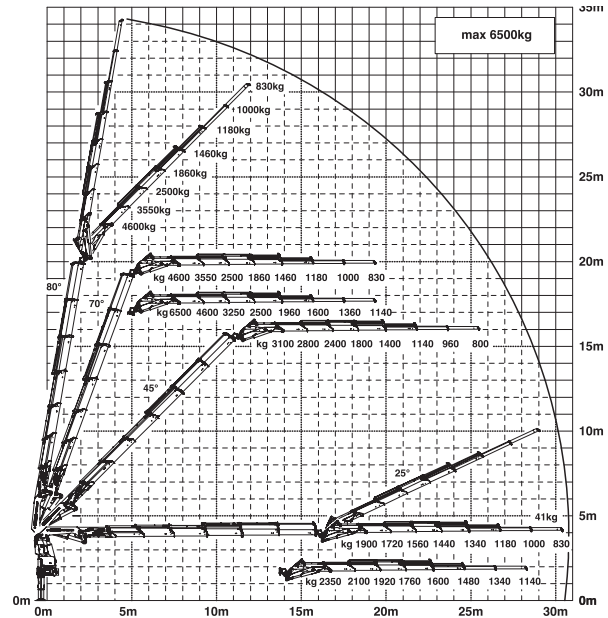

Technical Specifications (EN 12999 HC1 HD5/B3)

Max. lifting moment	74.7 mt/732.6 kNm
Max. lifting capacity	25000 kg/245.3 kN
Max. hydraulic outreach	20.4 m
Max. manual outreach	25.1 m
Max. outreach (with fly jib)	32.6 m
Slewing angle	endless
Slewing torque	
with 1 gear	4.5 mt/44.1 kNm
with 2 gears	7.0 mt/68.7 kNm

Stabilizer spread (std.)	8.6 m
Fitting space required	min. 1.56 m/max. 1.71 m
Width folded	2.55 m
Max. operating pressure	365 bar
Recommended pump capacity	from 100 l/min to 120 l/min
Dead weight (std.)	5908 kg

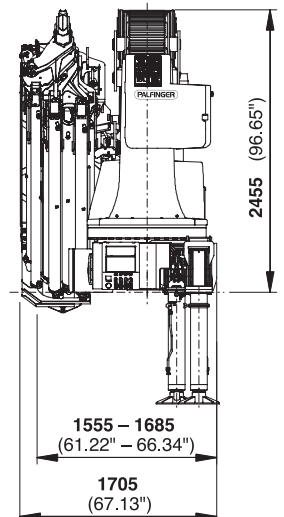
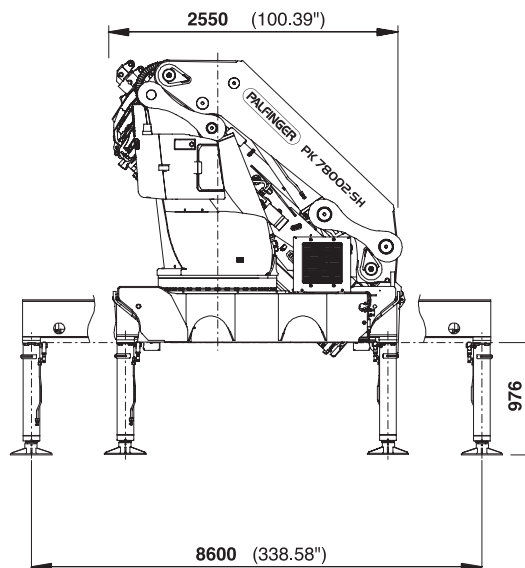
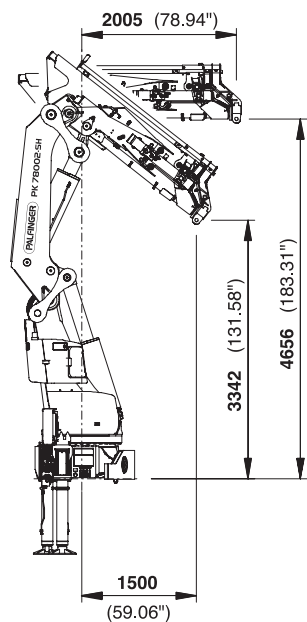

○ Stabilizer not active
● Stabilizer active
% Outrigger stroke

Max. occurring stabilizer force Fmax 270kN

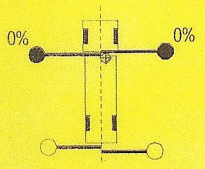

A: 440kg
B: 710kg
C: 1.620kg

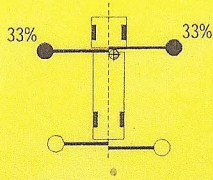

A: 860kg
B: 1.280kg
C: 2.500kg

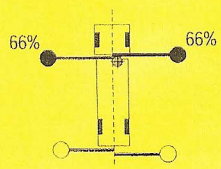
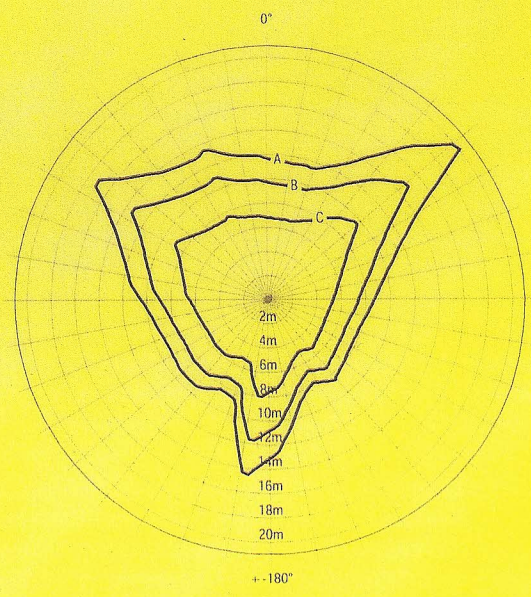
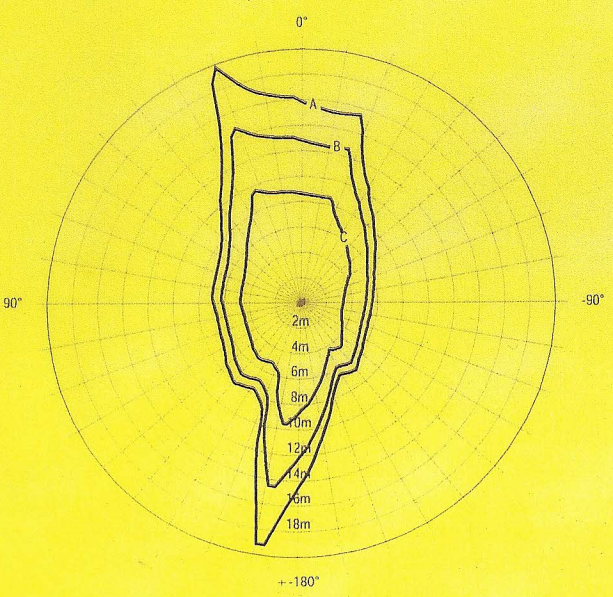

A: 1.820kg
B: 2.550kg
C: 4.450kg

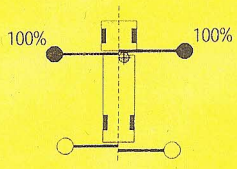

A: 2.700kg
B: 3.750kg
C: 6.300kg

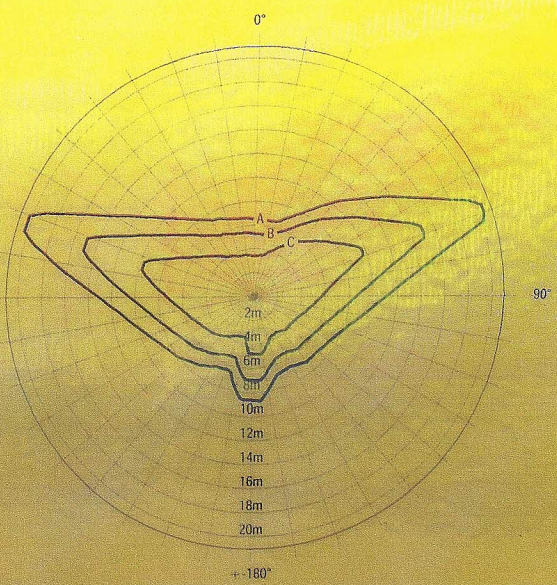
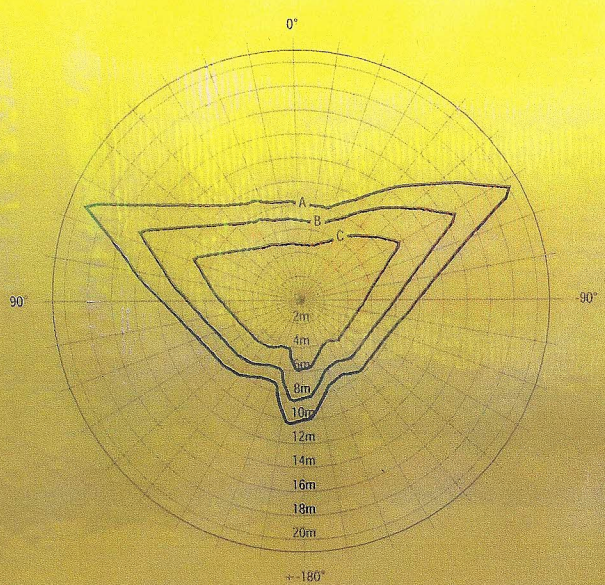

PALFINGER

PK 78002-SH G

LIFTING CAPACITY DIAGRAM

Stabilizer situation:

Fully supported

100152483 / S510-SKD

Mercedes-Benz|Actros

HPSC

Max. occurring stabilizer force Fmax 270kN

- Stabilizer not active
- Stabilizer active
- % Outrigger stroke

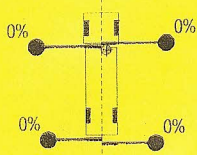

A: 1.820kg
B: 2.600kg
C: 4.450kg

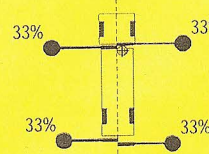

A: 2.400kg
B: 3.350kg
C: 5.700kg

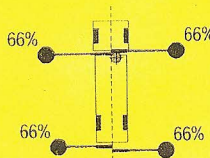
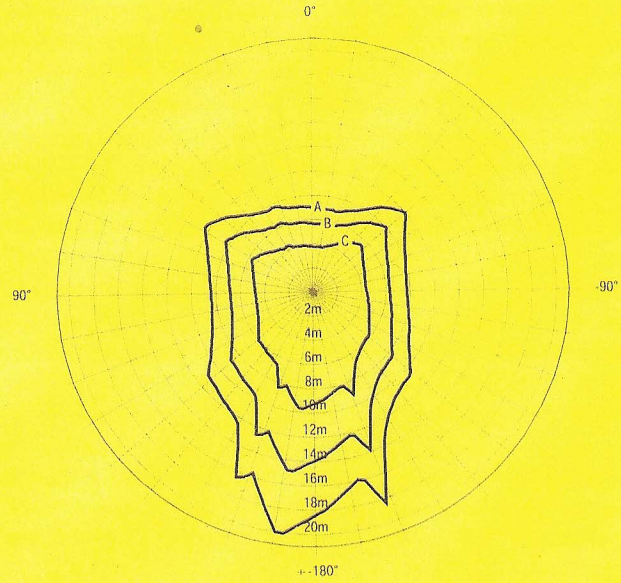
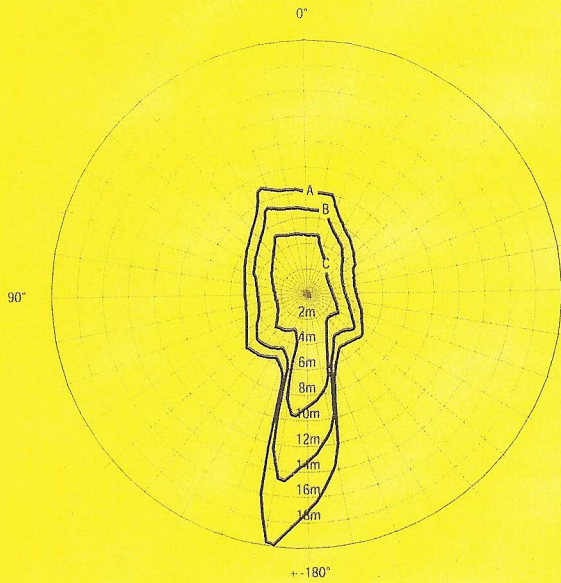

A: 2.700kg
B: 3.750kg
C: 6.300kg

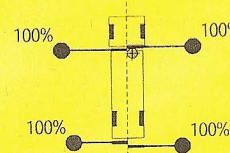

A: 2.700kg
B: 3.750kg
C: 6.300kg

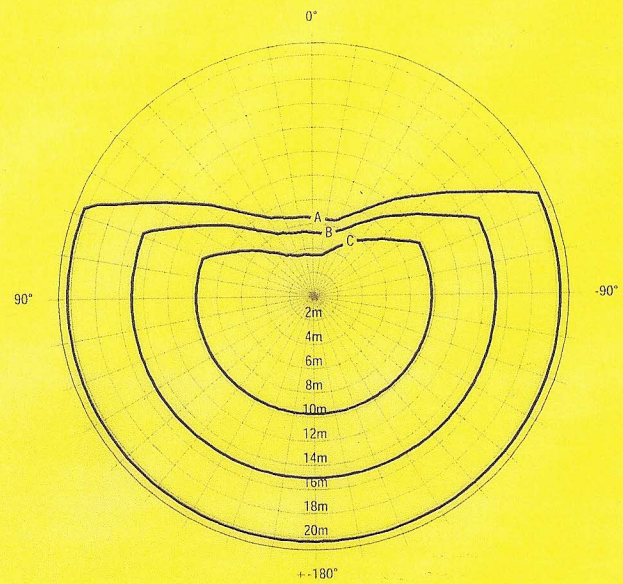
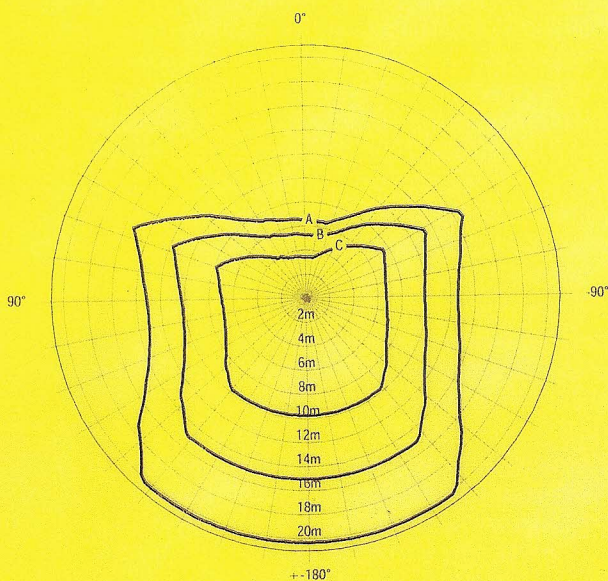

Load values are according to PALTRONIC parameters provided by the installer

Adjustment Date: 4122012

Version:
PCH1.1.3

Installer ID: FRPALFI02962E048/779306235665