

SENEBOGEN



186 kW



80 t



58 m



MAXCAB

683 HD

Teleskopkran
Telescopic Crane

- Traglasten 80 t
- Motorleistung 186 kW (253 PS)
- Modernste Load Sensing Hydraulikanlage
- Robuste, sehr servicefreundliche Konzeption
- Starkes B7 Traktoren-Laufwerk
- Kontinuierlich ausschiebbarer Teleskopausleger

Technische Daten



Motor

Deutz-Dieselmotor TCD2013L062V, mit Direkteinspritzung, wassergekühlt. Leistung nach DIN/ISO: 186 kW (253 PS) bei 2000 min⁻¹. TIER IIIa

Trockenluftfilter mit Zyklonvorabscheider, Sicherheitselement und Verschmutzungsanzeige im Fahrerhaus. Kraftstoffvolumen: 520 l.

Elektrische Anlage: 24 Volt
2 Kaltstart-Hochleistungsbatterien



Hydraulik

Load-Sensing-Hydrauliksystem mit lastdruckunabhängiger Volumenstromsteuerung, Druckabschneidung und energiesparneder Bedarfsstromsteuerung.

Durch die unabhängige und proportionale Zuteilung des Pumpenförderstroms können mehrere Arbeitsfunktionen gleichzeitig und unabhängig voneinander präzise gesteuert werden.

Geringe Strömungsverluste durch große Leitungsquerschnitte und großdimensionierte Steuerventile.

Load-Sensing-Leistungsregelung. Eigener, separater Hydraulikkreis für den Drehantrieb. Individuelle, feinfühligere Drehwerkssteuerung und optimale Bewegungsharmonie.

Axialkolbenpumpen mit Fördermenge 1 x 520 l/min, 1x 80 l/min Betriebsdruck 330 bar Hydrauliktankvolumen 1350/1150 l

Hydraulikölfilter mit Langzeitwechselintervall.

Gesunde Öltemperatur durch großdimensionierte Hydraulikkühlung. Zentrales Servicetableau zum einfachen und schnellen Überprüfen der gesamten Hydraulikanlage. Servokreuzschalthebel für Arbeitsbewegungen und Zusatzfunktionen nach ISO-System.



Drehantrieb

Separater Hydraulikkreis, Axialkolbenmotor, federbelastete, hydraulisch löfbbare Sicherheitslamellenbremse, Planetengetriebe und Drehwerksritzel. Großdimensionierter Drehkranz. Drehgeschwindigkeit 0 bis 2,0 min⁻¹, stufenlos regelbar. Im Motor integrierte Bremsventile sorgen für eine verschleißfreie Abbremsung.



Unterwagen 683 HD

Stabile Schweißkonstruktion in verwindungssteifer Bauweise. Hydraulischer Fahrtrieb je Fahrwerksseite durch einen Axialkolbenmotor über ein Kompaktplanetengetriebe im Fahrwerksrahmen integriert und zusätzlich durch Abdeckungen geschützt. Federbelastete hydraulisch löfbbare Lamellenbremsen als Sicherheitsfeststellbremsen.

Version I:

Unterwagen hydraulisch teleskopierbar Tele 83/390.

Version II:

Starlifter Unterwagen R87/440 in Breitspurversion, Spurbreite 4,4 m, 4 Unterwagen Abstützzylinder, abnehmbare Laufwerke für den Transport.

Wartungsfreies Traktorenlaufwerk B7 mit 3-Steg-Bodenplatten und hydraulischer Kettenspannung. Fahrgeschwindigkeit 0 – 2,5 km/h, 2-Stufen-Hydraulikfahrmotore. Sehr gute Geländegängigkeit durch hohe Zugleistung und gute Bodenfreiheit. Auf Wunsch: 900 mm Flachbodenplatten.



Oberwagen

Verwindungssteifer Oberrahmen mit durchgehenden Lagerschilden für optimierte Kräfteinleitung, präzisionsbearbeitet. Stahlbüchsen im Bereich der Auslegeranlenkungspunkte. Spezialschalldämmung für den Motor. Ausgezeichnetes Design.



Fahrerkabine

MAXcab

SENNEBOGEN maXcab mit Schiebetüre, exzellente Ergonomie, Heiz-Klimaautomatik mit Temperaturvorwahl und Frischluft / Umluftfilter, Komfortsitz luftgefedert optional einstellbar, ausgezeichnete Rundumsicht, SENNEBOGEN Diagnostic System



Arbeitsausrüstung

Teleskopausleger 5-teilig mit Rollenkopf, hydr. teleskopierbar. Hubzylinder und Teleskopzylinder mit Rohrbruchsicherheitsventilen.

Antrieb der Hubwinde über Axialkolbenmotor mit angebaurem Bremsventil und Planetengetriebe mit Sicherheitslamellenbremse im Ölbad. Zugkraft (1. Lage) max. 72 kN, Seilgeschwindigkeit max. 0 – 95 m/min, Seildurchmesser 20 mm,

Spitzenausleger neigbar (0°/20°/40°), sehr schnell und einfach ohne Hilfsgerät aufrüstbar, bei Nichteinsatz wird dieser seitlich am Grundausleger verriegelt. Komplette Sicherheitseinrichtung entsprechend den deutschen und europäischen Vorschriften. Elektronische Lastmomentbegrenzung (LMB) mit Klartextanzeige von Winkel, Auslegerlänge und Ausladung, Hubendschalter, Seilablaufsicherung.



Einsatzgewicht 683 HD

Einsatzgewicht mit Teleskopausleger 42 m, Spitzenausleger, 20 t Haken und Laufwerk B7 mit 700 mm 3 Steg- Bodenplatten, 1 Hubwinde

683 HD mit hydr. teleskopierbarem Unterwagen, Ballast 20,5 t und 13 t Unterwagenballast

ca.: **83,5 t**

683 HD Star-Lifter mit Breitspurunterwagen, Ballast 25,9 t und 6 t Unterwagenballast, 1 Hubwinde

ca.: **84,3 t**

Achtung:
Die angegebenen Gewichte können sich durch verschiedene Ausstattungen ändern.

Technische Änderungen vorbehalten!

- Lifting Capacity 80 t
- Engine output 186 kW (253 HP)
- State-of-the-art load-sensing hydraulic system
- Robust, very service-friendly design
- Strong B7 tractor tracks
- Continuously extension of the telescopic boom

Specifications



Engine

Deutz Diesel engine TDC2013L062V, with direct injection, water-cooled. Output as per DIN/ISO: 186 kW (253 HP) at 2000 rpm. TIER IIIa
 Dry air filter with cyclone preliminary filter, safety element and pollution indicator.
 Fuel tank capacity: 520 l.

Electric system 24 Volt
 2 highly efficient cold starting batteries



Hydraulic System

Load-sensing hydraulic-system. The variable displacement piston pump is equipped with pressure cut-off function and with a energy-saving flow-on-demand control.
 Through the independent and proportional feed of the oil flow all working functions can be operated parallelly, independently and very precisely.
 High efficiency through well designed hydraulic valves and lines.
 Separate hydraulic circuit for the swing drive. Individually and precisely swing operation.

Axial piston pumps
 Flow rates 1 x 520 l/min, 1 x 80 l/min working pressure 330 bar
 Hydraulic tank capacity 1350/1150 l

Hydraulic oil filter with long time change interval. Healthy oil temperature through high dimensioned hydraulic oil cooler. Central service board for easy and rapid check of complete hydraulic-system.
 Servo joy sticks for operating movements and additional functions as per ISO-System.



Slewing System

The slewing operation is driven independently through an axial piston motor, spring-loaded hydraulically releasable multiple-disk brake, planetary gear and pinion shaft.
 Large dimensioned slew bearing.
 Slewing speed 0 – 2.0 rpm, infinitely controllable.
 Hydraulic motor with integrated brake valves for reduction of wear in braking system to a minimum.



Undercarriage 683 HD

Each track is independently driven by an axial piston motor through planetary final drive. The drives are integrated into the track frames and protected by covers. Spring loaded hydraulically releasable multiple-disk brakes as safety parking brakes for reliable stopping.

Version I:
 Undercarriage hydraulically extendable Tele 83/390.
Version II:
 Starlifter undercarriage R87/440 in wide gauge version, gauge width 4.4 m, 4 hydr. cylinders, removable side frames for transport.

Maintenance-free track-type B7 with triple-bar-grouser track pads and hydraulic track-tensioning device.
 Travel speed 0-2.5 km/h, 2-speed travel motors. High traction force and good ground clearance to ensure excellent rough terrain travel.
 Option: 900 mm flat track shoes



Upper Structure

Torsion-free upper frame with continuous bearing-plates for optimal power introduction, precision machined. Steel-bushes for the boom-pivot. Special sound insulation for the engine. Excellent design.



Operator's Cab maXcab

SENNEBOGEN maXcab with sliding door, excellent ergonomics, automatic heating/air conditioning with temperature pre-select and fresh air/recirculation filter, air suspended comfort seat optionally adjustable, excellent 360° visibility, SENNEBOGEN Diagnostics System



Working Equipment

Telescopic five-section boom, hydr. extend- and retractable.
 Boom hoist cylinder and telescopic cylinder with safety check valves. Hoist winch via hydraulic motor with safety valve and planetary gear with safety multi-disk-brake in the oil bath.
 Line pull (1st layer) max. 72 kN, hoist speed max. 0 – 95 m/min, rope dia. 20 mm. Jib, adjustable (0°/20°/40°), it can be mounted very fast and very easily without any helping devices.

If fly jib is not used, it can be locked on the side of the main boom.
 Safety equipment according German and European regulations.
 Safe load indicator (SLI) with clear text indication of boom angle, boom length and radius, hoist end switch.



Service Weight 683 HD

Service weight with 42 m telescopic boom, jib, 20 t hook and track-type B7 with 700 mm triple-bar track shoes, 1 hoist winch

683 HD with hydraulically extendable undercarriage, counterweight 20,5 t, carbody counterweight 13 t

approx.: **83.5 t**

683 HD Star-Lifter with wide gauge undercarriage, counterweight 25.9 t, carbody counterweight 6 t, 1 hoist winch

approx.: **84.3 t**

Note:
 The shown weights may vary with different equipment!

Subject to technical modification!

Maße / Dimensions

683 HD mit hydraulisch teleskopierbarem Unterwagen Tele 83/390, Laufwerk B7
683 HD with hydraulically extendable undercarriage Tele 83/390, B7 tracks

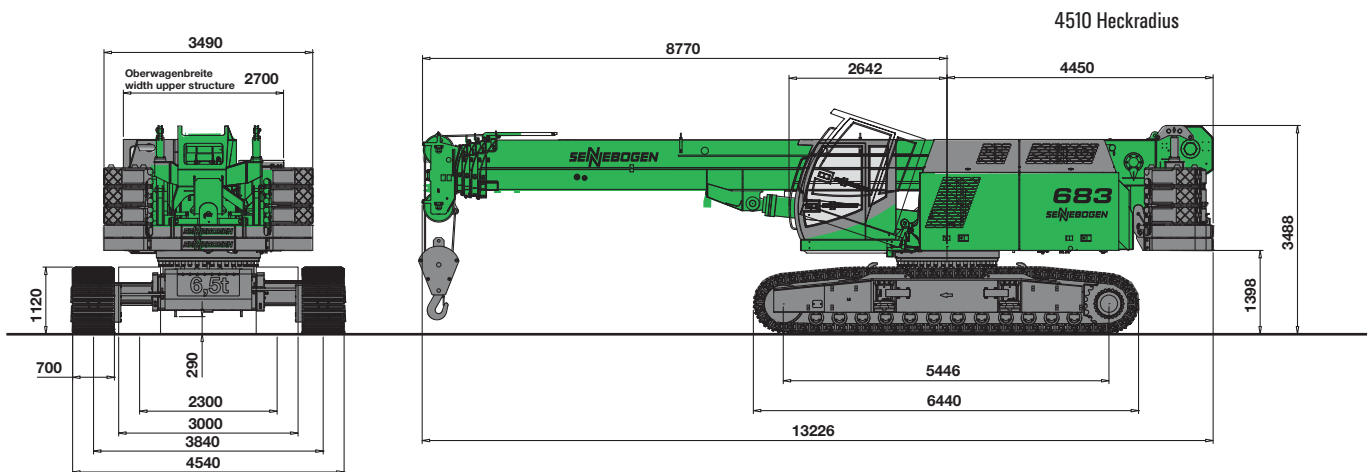

Grundmaschine mit Gegengewicht 20t + 13t Unterwagenballast
base machine with counterweight 20t + 13t carbody counterweight

683 HD mit Starlifter Unterwagen Tele 87/440, Laufwerk B7
683 HD with Star-Lifter undercarriage Tele 87/440, B7 tracks

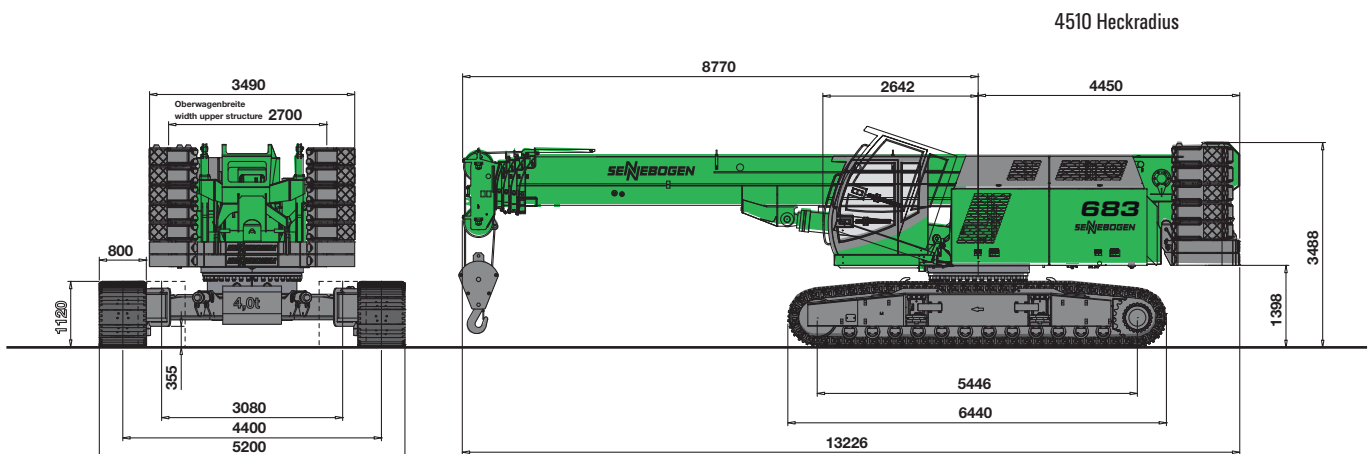

Grundmaschine mit Gegengewicht 25,9t + 6t Unterwagenballast
base machine with counterweight 25,9t + 6t carbody counterweight

Min. Unterwagenbreite bei Spurbreite von 3080 mm = 4050 mm
Min. width of undercarriage at gauge width of 3080 mm = 4050 mm

Kranausrüstung / Crane Equipment



10,8 - 42 m

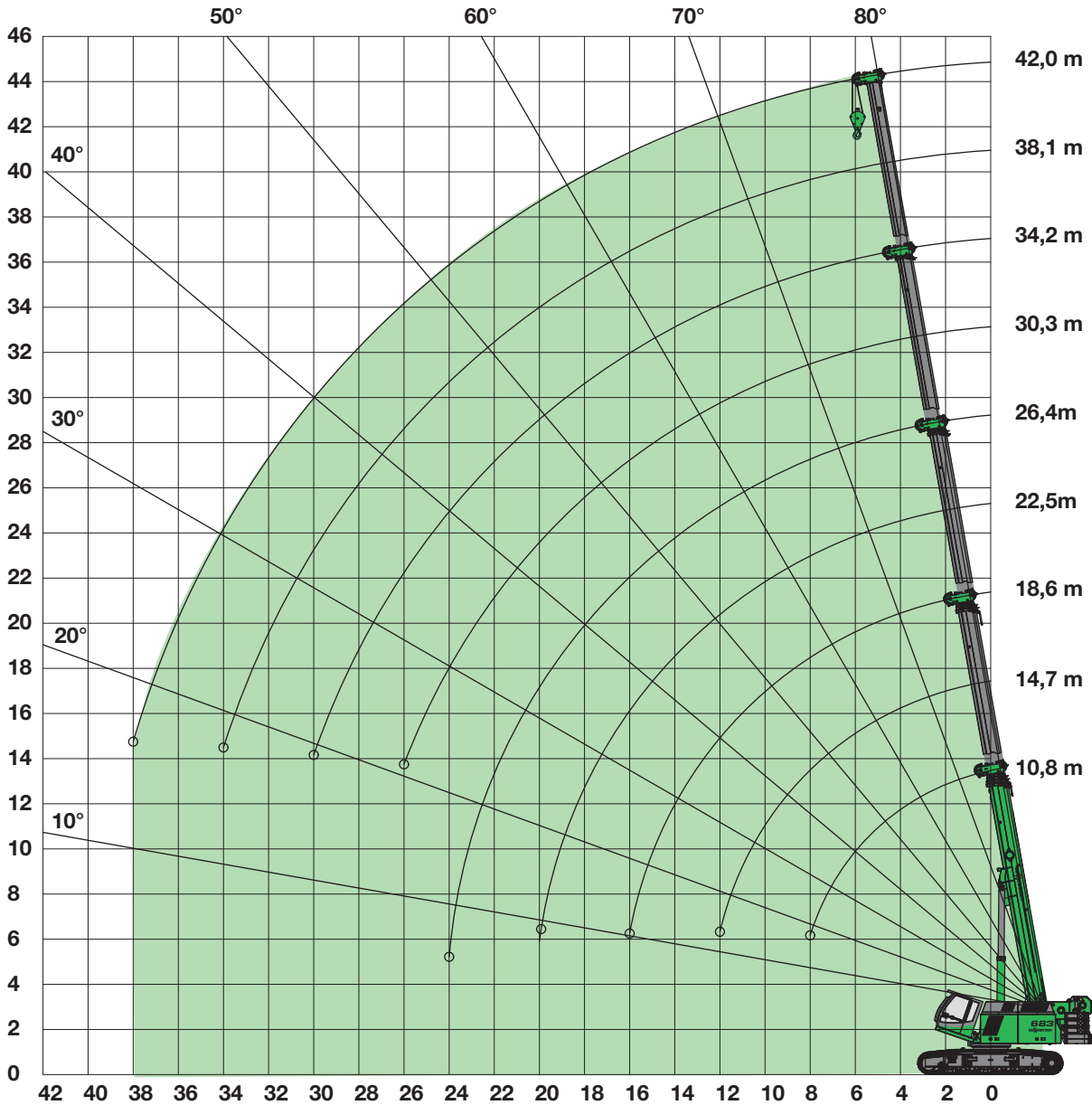

Kapazität capacity	Gewicht weight	Seileinsicherung und max. Traglast - no. of hoist reeving and max. rated load							
		8	7	6	5	4	3	2	1
10 t	200 kg								7.200 kg
20 t 1-rollig	325 kg						20.000 kg	14.400 kg	7.200 kg
50 t 3-rollig	675 kg		50.000 kg	43.200 kg	36.000 kg	28.800 kg	21.600 kg	14.400 kg	7.200 kg

Krantraglasten mit Teleunterwagen / Load charts with extendable undercarriage

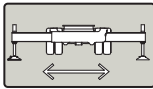

20,5 t



10,8 - 42 m

Unterwagenballast
carbody counterweight 13 t

Ausladung radius [m]	Auslegerlänge / boom length [m]									
	10,8	14,7	18,6	22,5	26,4	30,3	34,2	38,1	42,0	
2,5	80,0*									
3,0	72,5	50,0	40,0							
3,5	67,1	50,0	40,0							
4,0	62,4	50,0	40,0	31,5						
5,0	53,8	47,4	36,9	31,4	26,0					
6,0	40,4	37,6	32,9	28,6	24,6	19,0				
7,0	31,5	30,7	28,3	26,0	23,0	19,0	14,0			
8,0	25,6	24,8	23,9	22,7	21,3	18,9	14,0	12,0	9,5	
9,0		20,7	20,2	19,6	18,8	17,8	14,0	12,0	9,5	
10,0		17,5	17,1	17,0	16,4	16,1	14,0	12,0	9,5	
11,0		15,1	14,7	14,9	14,4	14,3	13,8	12,0	9,5	
12,0		13,1	12,7	12,9	12,8	12,7	12,6	11,8	9,5	
13,0			11,1	11,3	11,4	11,4	11,3	11,3	9,5	
14,0			9,7	9,9	10,0	10,2	10,2	10,3	9,5	
15,0			8,5	8,7	8,8	9,2	9,2	9,4	9,4	
16,0			7,5	7,7	7,8	8,2	8,4	8,6	8,7	
17,0				6,9	7,0	7,3	7,6	7,8	8,0	
18,0				6,1	6,2	6,6	6,9	7,2	7,3	
19,0				5,4	5,5	5,9	6,2	6,6	6,7	
20,0				4,8	4,9	5,3	5,6	6,0	6,2	
21,0					4,4	4,8	5,0	5,4	5,7	
22,0					3,9	4,3	4,5	4,9	5,3	
23,0					3,5	3,8	4,1	4,5	4,8	
24,0					3,1	3,4	3,7	4,1	4,4	
25,0						3,1	3,3	3,7	4,0	
26,0						2,7	3,0	3,4	3,7	
27,0							2,7	3,1	3,4	
28,0							2,4	2,8	3,1	
29,0							2,1	2,5	2,8	
30,0							1,9	2,3	2,6	
32,0								1,8	2,1	
34,0								1,4	1,7	
36,0									1,4	
38,0	Tab.-Nr.: 683R-75/1997/20.5/06.04 HA42									1,1
Strangzahl / parts reeving	12	7	6	5	4	3	2	2	2	
I	0%	50%	100%	100%	100%	100%	100%	100%	100%	
II	0%	0%	0%	50%	100%	100%	100%	100%	100%	
III	0%	0%	0%	0%	0%	50%	100%	100%	100%	
IV	0%	0%	0%	0%	0%	0%	0%	50%	100%	
Bei angebautem Spitzenanleger am Grundkörper müssen die Traglastwerte reduziert werden. When the jib is mounted at the basic main boom the rated loads have to be reduced.										
Traglastreduzierung reduction of load	1030kg	760kg	600kg	500kg	420kg	370kg	320kg	290kg	270kg	

Anmerkung:

- Die angegebenen Traglastwerte gelten für ebenen und festen Stand der Maschine.
- Traglastwerte sind in Tonnen angegeben und gelten für 360 Grad.
- Die Traglasten berücksichtigen die Normen DIN 15019/2 und ISO 4305
- Das Gewicht der Lastaufnahmemittel (Haken, Gehänge) ist von den Traglasten abzuziehen.
- Die Traglastwerte gelten für maximale Unterwagenspurbreite.
- Lastwerte müssen begrenzt oder vermindert werden, um ungünstige Bedingungen zu berücksichtigen, wie weichen oder unebenen Boden, schräge Gefälle, Wind, Seitenlasten, schwingende Lasten, Rucken oder plötzliches Stoppen der Ladungen, Unerfahrenheit des Personals, Fahren mit Last.
- Zulässiger Seilzug je Strang bei Kranbetrieb ist bei Seildurchmesser 20 mm - 7.200 kg
- Die angegebenen Traglastwerte sind nur zur Orientierung. Die jeweils gültigen Traglastwerte entnehmen Sie bitte den Tabellen in der Betriebsanleitung.
- Die Werte, die mit * gekennzeichnet sind, gelten nur mit Sonderausstattung.

Notes:

- The rated loads shown are based on the machine on firm level ground without travelling.
- The rated loads shown are in metric tons valid for 360 degrees swing.
- Liftcrane capacities are calculated to comply with DIN 15019/2 and ISO 4305
- The rated loads shown include the weight of all lifting attachments, such as hook and bucket.
- In operation crawler must be extended.
- The users must derate or limit the lifted loads to allow for adverse conditions such as soft or uneven ground, out of level conditions, wind, side loads, pendulum action, jerking or sudden stopping of loads, inexperience of personnel and travelling with a load.
- Max. single line pull for crane operation with rope diameter 20 mm - 7.200 kg
- The lifting capacities above are for reference only.
- For actual lifting capacities please refer to load chart in operator's manual.
- The values marked with * are valid with special equipment.

Krantraglasten Star-Lifter / Load charts Star-Lifter

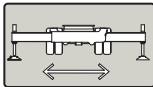

25,9 t



10,8 - 42 m

Unterwagenballast
carbody counterweight 6 t

Ausladung radius [m]	Auslegerlänge / boom length [m]									
	10,8	14,7	18,6	22,5	26,4	30,3	34,2	38,1	42,0	
2,5	80,0*									
3,0	72,5	50,0	40,0							
3,5	67,1	50,0	40,0							
4,0	62,4	50,0	40,0	31,5						
5,0	54,7	50,0	36,9	31,4	26,0					
6,0	48,3	45,1	32,9	28,6	24,6	19,0				
7,0	41,7	40,1	29,3	26,0	23,0	19,0	14,0			
8,0	33,4	32,6	26,2	23,6	21,3	18,9	14,0	12,0	9,5	
9,0		26,8	23,6	21,5	19,6	17,8	14,0	12,0	9,5	
10,0		22,6	21,5	19,6	18,0	16,7	14,0	12,0	9,5	
11,0		19,4	19,0	17,8	16,5	15,5	13,8	12,0	9,5	
12,0		16,9	16,5	16,3	15,1	14,3	13,1	11,8	9,5	
13,0			14,5	14,7	13,8	13,2	12,4	11,3	9,5	
14,0			12,8	13,0	12,7	12,2	11,7	10,8	9,5	
15,0			11,4	11,5	11,7	11,3	11,0	10,3	9,4	
16,0			10,1	10,3	10,4	10,5	10,3	9,8	9,1	
17,0				9,2	9,3	9,7	9,6	9,3	8,7	
18,0				8,3	8,4	8,8	9,0	8,9	8,3	
19,0				7,4	7,6	7,9	8,2	8,4	8,0	
20,0				6,7	6,8	7,2	7,5	7,9	7,6	
21,0					6,2	6,5	6,8	7,2	7,2	
22,0					5,6	6,0	6,2	6,6	6,9	
23,0					5,1	5,4	5,7	6,1	6,4	
24,0					4,6	4,9	5,2	5,6	5,9	
25,0						4,5	4,8	5,2	5,5	
26,0						4,1	4,4	4,8	5,1	
27,0							4,0	4,4	4,7	
28,0							3,6	4,0	4,4	
29,0							3,3	3,7	4,0	
30,0							3,0	3,4	3,7	
32,0								2,9	3,2	
34,0								2,4	2,7	
36,0									2,3	
38,0	Tab.-Nr.: 683R-75/2277/25.9/11.09HA42									2,0
Strangzahl / parts reeving	12	7	6	5	4	3	2	2	2	
I	0%	50%	100%	100%	100%	100%	100%	100%	100%	
II	0%	0%	0%	50%	100%	100%	100%	100%	100%	
III	0%	0%	0%	0%	0%	50%	100%	100%	100%	
IV	0%	0%	0%	0%	0%	0%	0%	50%	100%	
	Bei angebaitem Spitzenanleger am Grundkörper müssen die Traglastwerte reduziert werden. When the jib is mounted at the basic main boom the rated loads have to be reduced.									
Traglastreduzierung reduction of load	1030kg	760kg	600kg	500kg	420kg	370kg	320kg	290kg	270kg	

Anmerkung:

- Die angegebenen Traglastwerte gelten für ebenen und festen Stand der Maschine.
- Traglastwerte sind in Tonnen angegeben und gelten für 360 Grad.
- Die Traglasten berücksichtigen die Normen DIN 15019/2 und ISO 4305
- Das Gewicht der Lastaufnahmemittel (Haken, Gehänge) ist von den Traglasten abzuziehen.
- Die Traglastwerte gelten für maximale Unterwagenspurbreite.
- Lastwerte müssen begrenzt oder vermindert werden, um ungünstige Bedingungen zu berücksichtigen, wie weichen oder unebenen Boden, schräge Gefälle, Wind, Seitenlasten, schwingende Lasten, Rucken oder plötzliches Stoppen der Ladungen, Unerfahrenheit des Personals, Fahren mit Last.
- Zulässiger Seilzug je Strang bei Kranbetrieb ist bei Seildurchmesser 20 mm - 7.200 kg
- Die angegebenen Traglastwerte sind nur zur Orientierung. Die jeweils gültigen Traglastwerte entnehmen Sie bitte den Tabellen in der Betriebsanleitung.
- Die Werte, die mit * gekennzeichnet sind, gelten nur mit Sonderausstattung.

Notes:

- The rated loads shown are based on the machine on firm level ground without travelling.
- The rated loads shown are in metric tons valid for 360 degrees swing.
- Liftcrane capacities are calculated to comply with DIN 15019/2 and ISO 4305
- The rated loads shown include the weight of all lifting attachments, such as hook and bucket.
- In operation crawler must be extended.
- The users must derate or limit the lifted loads to allow for adverse conditions such as soft or uneven ground, out of level conditions, wind, side loads, pendulum action, jerking or sudden stopping of loads, inexperience of personnel and travelling with a load.
- Max. single line pull for crane operation with rope diameter 20 mm - 7.200 kg
- The lifting capacities above are for reference only.
- For actual lifting capacities please refer to load chart in operator's manual.
- The values marked with * are valid with special equipment.

Krausrüstung / Crane Equipment



10 m / 16 m

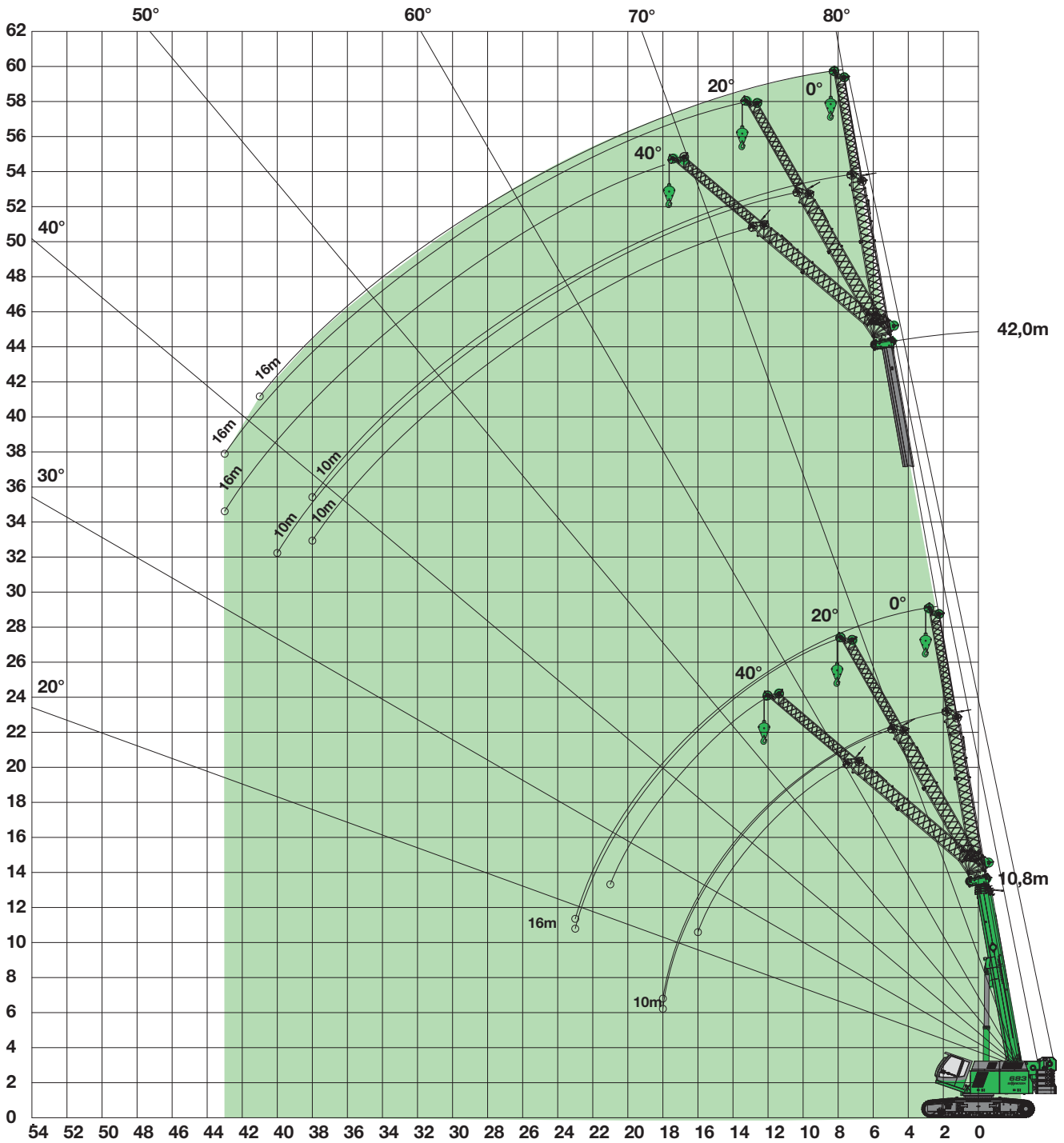

Krantraglasten Spitzenausleger / Load charts jib

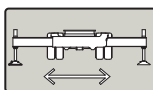

10,8 - 42 m



10 m

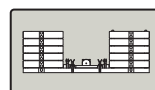

20,5 & 25,9 t

Ausladung / radius [m]	Auslegerlänge - boom length [m]														
	10,8			18,6			26,4			34,2			42,0		
	0°	20°	40°	0°	20°	40°	0°	20°	40°	0°	20°	40°	0°	20°	40°
3,0	13,7														
4,0	12,2														
5,0	10,9														
6,0	9,7	6,9		11,5											
7,0	8,7	6,4		10,7				10,9							
8,0	7,9	6,0	5,0	9,9	6,7			10,4							
9,0	7,2	5,7	4,8	9,2	6,3			10,0			8,5				
10,0	6,6	5,4	4,6	8,6	6,1	4,9	9,5	6,4			8,5				
12,0	5,7	4,9	4,3	7,4	5,6	4,6	8,7	6,0	4,7	8,3	6,1		5,2		
14,0	5,0	4,4	4,1	6,5	5,2	4,4	7,8	5,6	4,6	7,8	5,7	4,6	5,2	5,2	
16,0	4,5	4,2	4,0	5,8	4,8	4,2	7,1	5,3	4,4	7,3	5,4	4,5	5,2	5,2	4,4
18,0	4,1	4,0		5,3	4,5	4,1	6,4	5,0	4,3	6,8	5,2	4,4	5,2	5,2	4,2
20,0				4,9	4,3	4,0	5,8	4,8	4,2	5,7	5,0	4,3	5,2	5,0	4,2
22,0				4,6	4,1		4,8	4,5	4,0	4,7	4,7	4,2	4,9	4,8	4,1
24,0				4,2	4,0		3,9	4,3	3,9	3,9	4,4	4,1	4,1	4,5	4,1
26,0							3,2	3,5	3,5	3,2	3,6	3,8	3,4	3,9	4,0
28,0							2,6	2,8		2,6	2,9	3,1	2,8	3,3	3,5
30,0							2,0	2,2		2,1	2,3	2,4	2,3	2,7	2,9
32,0							1,6	1,7		1,5	1,8	1,9	1,9	2,2	2,3
34,0							1,2			1,1	1,3		1,5	1,7	1,7
36,0										0,8	0,9		1,2	1,3	1,4
38,0													0,8	0,9	1,0
40,0															
Strangzahl parts reeving	2	1	1	2	1	1	2	1	1	2	1	1	1	1	1
I	0%			100%			100%			100%			100%		
II	0%			0%			100%			100%			100%		
III	0%			0%			0%			100%			100%		
IV	0%			0%			0%			0%			100%		

Anmerkung:

- Die angegebenen Traglastwerte gelten für ebenen und festen Stand der Maschine.
- Traglastwerte sind in Tonnen angegeben und gelten für 360 Grad.
- Die Traglasten berücksichtigen die Normen DIN 15019/2 und ISO 4305
- Das Gewicht der Lastaufnahmemittel (Haken, Gehänge) ist von den Traglasten abzuziehen.
- Die Traglastwerte gelten für maximale Unterwagenspurbreite.
- Lastwerte müssen begrenzt oder vermindert werden, um ungünstige Bedingungen zu berücksichtigen, wie weichen oder unebenen Boden, schräge Gefälle, Wind, Seitenlasten, schwingende Lasten, Rucken oder plötzliches Stoppen der Ladungen, Unerfahrenheit des Personals, Fahren mit Last.
- Zulässiger Seilzug je Strang bei Kranbetrieb ist bei Seildurchmesser 20 mm - 7.200 kg
- Die angegebenen Traglastwerte sind nur zur Orientierung. Die jeweils gültigen Traglastwerte entnehmen Sie bitte den Tabellen in der Betriebsanleitung.

Alle Angaben vorläufig. Änderungen vorbehalten.

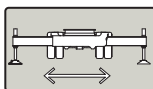

10,8 - 42 m



16 m



20,5 & 25,9 t

Ausladung radius [m]	Auslegerlänge - boom length [m]														
	10,8			18,6			26,4			34,2			42,0		
	0°	20°	40°	0°	20°	40°	0°	20°	40°	0°	20°	40°	0°	20°	40°
4,0	6,1														
5,0	5,6														
6,0	5,1			5,6											
7,0	4,7			5,2											
8,0	4,3			4,9											
9,0	4,0			4,6											
10,0	3,7	3,0		4,3			4,9								
12,0	3,2	2,7		3,9	2,8		4,2			4,2					
14,0	2,9	2,5	2,2	3,5	2,7		3,9	2,8		4,0			3,4		
16,0	2,6	2,3	2,0	3,1	2,5	2,1	3,6	2,7		3,7	2,7		3,4		
18,0	2,4	2,1	1,9	2,9	2,4	2,0	3,3	2,5	2,1	3,5	2,6		3,3		
20,0	2,2	2,0	1,8	2,7	2,2	2,0	3,0	2,4	2,0	3,3	2,5	2,1	3,2	2,5	
22,0	2,0	1,9	1,8/21m	2,5	2,1	1,9	2,8	2,3	2,0	3,1	2,4	2,0	3,0	2,4	2,0
24,0	1,9/23m	1,8/23m		2,3	2,0	1,8	2,7	2,2	1,9	2,9	2,3	2,0	2,9	2,3	2,0
26,0				2,1	1,9	1,8	2,5	2,1	1,9	2,8	2,2	1,9	2,8	2,2	1,9
28,0				2,0	1,9	1,8/27m	2,4	2	1,8	2,6	2,1	1,9	2,7	2,2	1,9
30,0				1,9	1,8		2,2	1,9	1,8	2,5	2,1	1,8	2,6	2,1	1,9
32,0							2,1	1,9	1,8/31m	2,4	2,0	1,8	2,5	2,1	1,8
34,0							2,0	1,8		2,0	1,9	1,8	2,2	2,0	1,8
36,0							1,6	1,8		1,6	1,9	1,8	1,8	2,0	1,8
38,0							1,3	1,5/37m		1,3	1,6	1,8/37m	1,5	1,9	1,8
40,0							1,0/39m			1,0/39m	1,3		1,3	1,6	1,8
42,0										1,0/41m			1,0/41m	1,3	1,5
44,0													1,0/43m	1,2/43m	
Strangzahl parts reeving	1	1	1	1	1	1	1	1	1	1	1	1	1	1	1
I	0%			100%			100%			100%			100%		
II	0%			0%			100%			100%			100%		
III	0%			0%			0%			100%			100%		
IV	0%			0%			0%			0%			100%		

Notes:

- The rated loads shown are based on the machine on firm level ground without travelling.
- The rated loads shown are in metric tons valid for 360 degrees swing.
- Liftcrane capacities are calculated to comply with DIN 15019/2 and ISO 4305
- The rated loads shown include the weight of all lifting attachments, such as hook and bucket.
- In operation crawler must be extended.
- The users must derate or limit the lifted loads to allow for adverse conditions such as soft or uneven ground, out of level conditions, wind, side loads, pendulum action, jerking or sudden stopping of loads, inexperience of personnel and travelling with a load.
- Max. single line pull for crane operation with rope diameter 20 mm - 7.200 kg
- The lifting capacities above are for reference only. For actual lifting capacities please refer to load chart in operator's manual.

All informations are subject to be changed without prior notice.

Krantraglasten mit Teleunterwagen / Load charts with extendable undercarriage

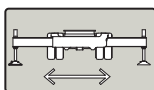

20,5 t



10,8 - 42 m

Unterwagenballast
carbody counterweight 13 t

Position 1

Ausladung Radius[m]	Auslegerlänge / boom length [m]								
	10,8	14,7	18,6	22,5	26,4	30,3	34,2	38,1	42,0
3,0	14,4								
3,5	14,4								
4,0	14,4	14,4							
5,0	14,4	14,4							
6,0	14,4	14,4	14,4						
7,0	14,4	14,4	14,4	14,4					
8,0	14,4	14,4	14,4	14,4	14,4				
9,0	14,4	14,4	14,4	14,4	14,4	14,4			
10,0	14,4 / 9,5	14,4	14,4	14,4	14,4	14,4			
11,0		14,4	14,4	14,4	14,4	14,3	13,2		
12,0		13,1	12,7	12,9	12,8	12,7	12,6	11,0	
13,0		11,5	11,1	11,3	11,4	11,4	11,3	10,8	
14,0		10,1 / 13,5	9,7	9,9	10,0	10,2	10,2	10,3	9,0
15,0			8,5	8,7	8,8	9,2	9,2	9,4	8,9
16,0			7,5	7,7	7,8	8,2	8,4	8,6	8,7
17,0			6,6	6,9	7,0	7,3	7,6	7,8	8,0
18,0			5,8 / 17,5	6,1	6,2	6,6	6,9	7,2	7,3
19,0				5,4	5,5	5,9	6,2	6,6	6,7
20,0				4,8	4,9	5,3	5,6	6,0	6,2
21,0				4,3	4,4	4,8	5,0	5,4	5,7
22,0				3,7 / 21,5	3,9	4,3	4,5	4,9	5,3
23,0					3,5	3,8	4,1	4,5	4,8
24,0					3,1	3,4	3,7	4,1	4,4
25,0					2,7	3,1	3,3	3,7	4,0
26,0					2,4 / 25,5	2,7	3,0	3,4	3,7
27,0						2,4	2,7	3,1	3,4
28,0						2,1 / 27,5	2,4	2,8	3,1
29,0							2,1	2,5	2,8
30,0							1,9	2,3	2,6
32,0							1,4	1,8	2,1
34,0								1,4	1,7
36,0								1,0 / 35,5	1,4
38,0									1,1
40,0									1,1
Tab.-Nr.: 683R-75/1997/20.5/02.05 S1									
Strangzahl / parts reeving	2	2	2	2	2	2	2	2	2
I	0%	50%	100%	100%	100%	100%	100%	100%	100%
II	0%	0%	0%	50%	100%	100%	100%	100%	100%
III	0%	0%	0%	0%	0%	50%	100%	100%	100%
IV	0%	0%	0%	0%	0%	0%	0%	50%	100%

Schnabelausleger 14,4 t jib 14,4 t

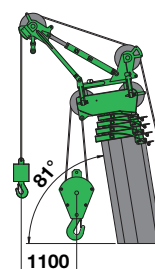
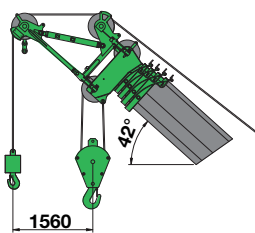

Position 1

Position 2

Position 2

Ausladung Radius[m]	Auslegerlänge / boom length [m]								
	10,8	14,7	18,6	22,5	26,4	30,3	34,2	38,1	42,0
3,0	14,4	14,4	14,4						
3,5	14,4	14,4	14,4						
4,0	14,4	14,4	14,4	14,4					
5,0	14,4	14,4	14,4	14,4					
6,0	14,4	14,4	14,4	14,4	14,4				
7,0	14,4	14,4	14,4	14,4	14,4	14,4			
8,0	14,4	14,4	14,4	14,4	14,4	14,4	14,0		
9,0	14,4	14,4	14,4	14,4	14,4	14,4	14,0	11,0	9,0
10,0	14,4 / 9,5	14,4	14,4	14,4	14,4	14,4	13,9	11,0	9,0
11,0		14,4	14,4	14,4	14,4	14,3	13,8	11,0	9,0
12,0		13,1	12,7	12,9	12,8	12,7	12,6	11,0	9,0
13,0		11,5	11,1	11,3	11,4	11,4	11,3	10,8	9,0
14,0		10,1 / 13,5	9,7	9,9	10,0	10,2	10,2	10,3	9,0
15,0			8,5	8,7	8,8	9,2	9,2	9,4	8,9
16,0			7,5	7,7	7,8	8,2	8,4	8,6	8,7
17,0			6,6	6,9	7,0	7,3	7,6	7,8	8,0
18,0			5,8 / 17,5	6,1	6,2	6,6	6,9	7,2	7,3
19,0				5,4	5,5	5,9	6,2	6,6	6,7
20,0				4,8	4,9	5,3	5,6	6,0	6,2
21,0				4,3	4,4	4,8	5,0	5,4	5,7
22,0				3,7 / 21,5	3,9	4,3	4,5	4,9	5,3
23,0					3,5	3,8	4,1	4,5	4,8
24,0					3,1	3,4	3,7	4,1	4,4
25,0					2,7	3,1	3,3	3,7	4,0
26,0					2,4 / 25,5	2,7	3,0	3,4	3,7
27,0						2,4	2,7	3,1	3,4
28,0						2,1 / 27,5	2,4	2,8	3,1
29,0							2,1	2,5	2,8
30,0							1,9	2,3	2,6
32,0							1,4	1,8	2,1
34,0								1,4	1,7
36,0								1,0 / 35,5	1,4
38,0									1,1
Tab.-Nr.: 683R-75/1997/20.5/02.05 S2									
Strangzahl / parts reeving	2	2	2	2	2	2	2	2	2
I	0%	50%	100%	100%	100%	100%	100%	100%	100%
II	0%	0%	0%	50%	100%	100%	100%	100%	100%
III	0%	0%	0%	0%	0%	50%	100%	100%	100%
IV	0%	0%	0%	0%	0%	0%	0%	50%	100%

Anmerkung:

- Die angegebenen Traglastwerte gelten für ebenen und festen Stand der Maschine.
- Traglastwerte sind in Tonnen angegeben und gelten für 360 Grad.
- Die Traglasten berücksichtigen die Normen DIN 15019/2 und ISO 4305
- Das Gewicht der Lastaufnahmemittel (Haken, Gehänge) ist von den Traglasten abzuziehen.
- Die Traglastwerte gelten für maximale Unterwagenpurbreite.
- Lastwerte müssen begrenzt oder vermindert werden, um ungünstige Bedingungen zu berücksichtigen, wie weichen oder unebenen Boden, schräge Gefälle, Wind, Seitenlasten, schwingende Lasten, Rucken oder plötzliches Stoppen der Ladungen, Unerfahrenheit des Personals, Fahren mit Last.
- Zulässiger Seilzug je Strang bei Kranbetrieb ist bei Seildurchmesser 20 mm - 7.200 kg
- Die angegebenen Traglastwerte sind nur zur Orientierung. Die jeweils gültigen Traglastwerte entnehmen Sie bitte den Tabellen in der Betriebsanleitung.

Alle Angaben vorläufig. Änderungen vorbehalten.

Krantraglasten Star-Lifter / Load charts Star-Lifter

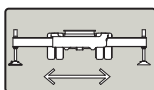

25,9 t



10,8 - 42 m

**Unterwagenballast
carbody counterweight 6 t**

Position 1

Ausladung Radius[m]	Auslegerlänge / boom length [m]								
	10,8	14,7	18,6	22,5	26,4	30,3	34,2	38,1	42,0
3,0	14,4								
3,5	14,4								
4,0	14,4	14,4							
5,0	14,4	14,4							
6,0	14,4	14,4	14,4						
7,0	14,4	14,4	14,4	14,4					
8,0	14,4	14,4	14,4	14,4	14,4				
9,0	14,4	14,4	14,4	14,4	14,4				
10,0	14,4 / 9,5	14,4	14,4	14,4	14,4	14,4			
11,0		14,4	14,4	14,4	14,4	14,4	13,2		
12,0		14,4	14,4	14,4	14,4	14,3	12,6	11,0	
13,0		14,4	14,4	14,4	13,8	13,2	11,9	10,8	
14,0		13,2 / 13,5	12,8	13,0	12,7	12,2	11,3	10,4	9,0
15,0			11,4	11,5	11,7	11,3	10,7	10,0	8,9
16,0			10,1	10,3	10,4	10,5	10,1	9,6	8,7
17,0			9,0	9,2	9,3	9,7	9,6	9,1	8,4
18,0			8,1 / 17,5	8,3	8,4	8,8	9,0	8,7	8,1
19,0				7,4	7,6	7,9	8,2	8,2	7,8
20,0				6,7	6,8	7,2	7,5	7,8	7,4
21,0				6,1	6,2	6,5	6,8	7,2	7,0
22,0				5,5 / 21,5	5,6	6,0	6,2	6,6	6,6
23,0					5,1	5,4	5,7	6,1	6,4
24,0					4,6	4,9	5,2	5,6	5,9
25,0					4,2	4,5	4,8	5,2	5,5
26,0					3,8 / 25,5	4,1	4,4	4,8	5,1
27,0						3,7	4,0	4,4	4,7
28,0						3,3 / 27,5	3,6	4,0	4,4
29,0							3,3	3,7	4,0
30,0							3,0	3,4	3,7
32,0							2,5 / 31,5	2,9	3,2
34,0								2,4	2,7
36,0								1,9 / 35,5	2,3
38,0									2,0
40,0									1,7 / 39,5

Tab.-Nr.: 683R-75/2277/25.9/02.07 S1

Strangzahl / parts reeving	2	2	2	2	2	2	2	2	2
I	0%	50%	100%	100%	100%	100%	100%	100%	100%
II	0%	0%	0%	50%	100%	100%	100%	100%	100%
III	0%	0%	0%	0%	0%	50%	100%	100%	100%
IV	0%	0%	0%	0%	0%	0%	0%	50%	100%

**Schnabelausleger 14,4 t
jib 14,4 t**

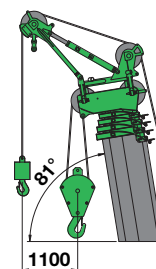
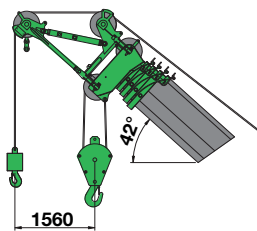

Position 1

Position 2

Position 2

Ausladung Radius[m]	Auslegerlänge / boom length [m]								
	10,8	14,7	18,6	22,5	26,4	30,3	34,2	38,1	42,0
3,0	14,4	14,4	14,4						
3,5	14,4	14,4	14,4						
4,0	14,4	14,4	14,4	14,4					
5,0	14,4	14,4	14,4	14,4					
6,0	14,4	14,4	14,4	14,4	14,4				
7,0	14,4	14,4	14,4	14,4	14,4	14,4			
8,0	14,4	14,4	14,4	14,4	14,4	14,4	14,0		
9,0	14,4	14,4	14,4	14,4	14,4	14,4	14,0	11,0	9,0
10,0	14,4 / 9,5	14,4	14,4	14,4	14,4	14,4	13,9	11,0	9,0
11,0		14,4	14,4	14,4	14,4	14,4	13,2	11,0	9,0
12,0		14,4	14,4	14,4	14,4	14,3	12,6	11,0	9,0
13,0		14,4	14,4	14,4	14,4	13,8	13,2	11,9	10,8
14,0		13,2 / 13,5	12,8	13,0	12,7	12,2	11,3	10,4	9,0
15,0			11,4	11,5	11,7	11,3	10,7	10,0	8,9
16,0			10,1	10,3	10,4	10,5	10,1	9,6	8,7
17,0			9,0	9,2	9,3	9,7	9,6	9,1	8,4
18,0			8,1 / 17,5	8,3	8,4	8,8	9,0	8,7	8,1
19,0				7,4	7,6	7,9	8,2	8,2	7,8
20,0				6,7	6,8	7,2	7,5	7,8	7,4
21,0				6,1	6,2	6,5	6,8	7,2	7,0
22,0				5,5 / 21,5	5,6	6,0	6,2	6,6	6,6
23,0					5,1	5,4	5,7	6,1	6,4
24,0					4,6	4,9	5,2	5,6	5,9
25,0					4,2	4,5	4,8	5,2	5,5
26,0					3,8 / 25,5	4,1	4,4	4,8	5,1
27,0						3,7	4,0	4,4	4,7
28,0						3,3	3,6	4,0	4,4
29,0							3,3	3,7	4,0
30,0							3,0	3,4	3,7
32,0							2,5 / 31,5	2,9	3,2
34,0								2,4	2,7
36,0								1,9 / 35,5	2,3
38,0									2,0
40,0									1,7 / 39,5

Tab.-Nr.: 683R-75/2277/25.9/02.07 S2

Strangzahl / parts reeving	2	2	2	2	2	2	2	2	2
I	0%	50%	100%	100%	100%	100%	100%	100%	100%
II	0%	0%	0%	50%	100%	100%	100%	100%	100%
III	0%	0%	0%	0%	0%	50%	100%	100%	100%
IV	0%	0%	0%	0%	0%	0%	0%	50%	100%

Notes:

- The rated loads shown are based on the machine on firm level ground without travelling.
- The rated loads shown are in metric tons valid for 360 degrees swing.
- Liftcrane capacities are calculated to comply with DIN 15019/2 and ISO 4305
- The rated loads shown include the weight of all lifting attachments, such as hook and bucket.
- In operation crawler must be extended.
- The users must derate or limit the lifted loads to allow for adverse conditions such as soft or uneven ground, out of level conditions, wind, side loads, pendulum action, jerking or sudden stopping of loads, inexperience of personnel and travelling with a load.
- Max. single line pull for crane operation with rope diameter 20 mm - 7.200 kg
- The lifting capacities above are for reference only. For actual lifting capacities please refer to load chart in operator's manual.

All informations are subject to be changed without prior notice.

Hubarbeitsbühne - Arbeitsbereich / Access platform - working area

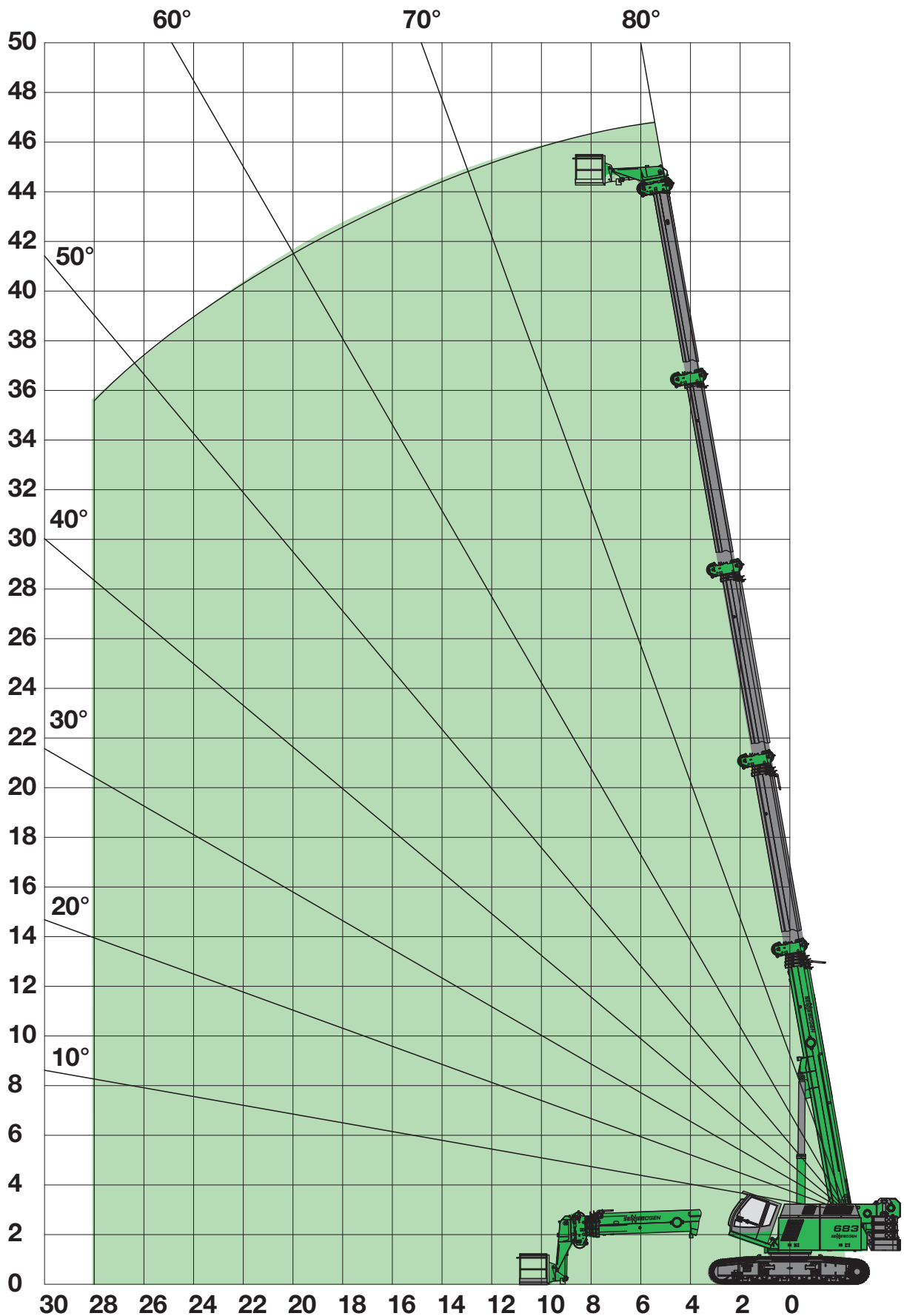

Transportmaße und Gewichte / transport dimensions and weights

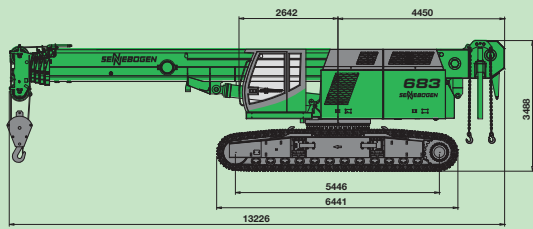

683 Grundmaschine mit Teleskopunterwagen Tele 83/390 und 700 mm 3-Steg Bodenplatten
683 basic machine with extendable undercarriage Tele 83/390 and 700 mm triple-bar-shoes

Gewicht / Weight kg 48.600 - 52.400

Transportbreite Grundmaschine - transport width of base machine
Bodenplatten/ width of tracks shoes 700 mm 800 mm 900 mm 1000 mm
Min.Transportbreite / min. transport width 3000 mm 3300 mm 3400 mm 3600 mm

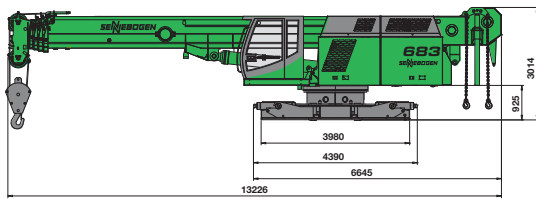

683 Grundmaschine mit Star-Lifter Unterwagen R87/440
683 basic machine with Star-Lifter undercarriage R87/440

Gewicht/ weight kg 32.400 - 36.200

Breite / width mm 3.000

Achtung: Die angegebenen Gewichte können sich durch verschiedene Ausstattungen ändern.

Note: The shown weights may vary with different equipment!

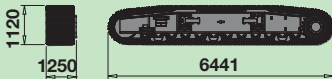

Raupenlaufwerk
Crawler

Gewicht: 9.300 - 10.500 kg (2x)
weight: 9.300 - 10.500 kg (2x)

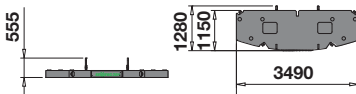

Ballastgrundplatte
Counterweight base plate

Gewicht: 5200 kg (1x)
weight: 5200 kg (1x)

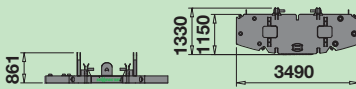

Ballastgrundplatte
Counterweight base plate

Gewicht: 5400 kg (1x)
weight: 5400 kg (1x)



Gegengewicht 10 Stück
Counterweight 10 pieces

Gewicht: 1500 kg (10x)
weight: 1500 kg (10x)

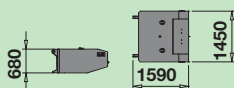

Unterwagenballast
Carbody Counterweight

Gewicht: 6500 kg / 3000kg (2x)
weight: 6500 kg / 3000kg (2x)

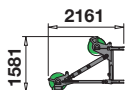

Schnabelausleger
auxiliary jib

Gewicht: 290 kg
weight: 290 kg

Breite: 650 mm
width: 650 mm

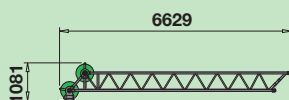

6m Verlängerung für Klappspitze
6m extension for jib

Gewicht: 450 kg
weight: 450 kg

Breite: 650 mm
width: 650 mm

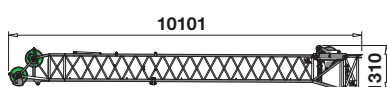

10m Klappspitze
10m jib

Gewicht: 1000 kg
weight: 1000 kg

Breite: 850 mm
width: 850 mm

Selbstmontagesystem / self assembly system

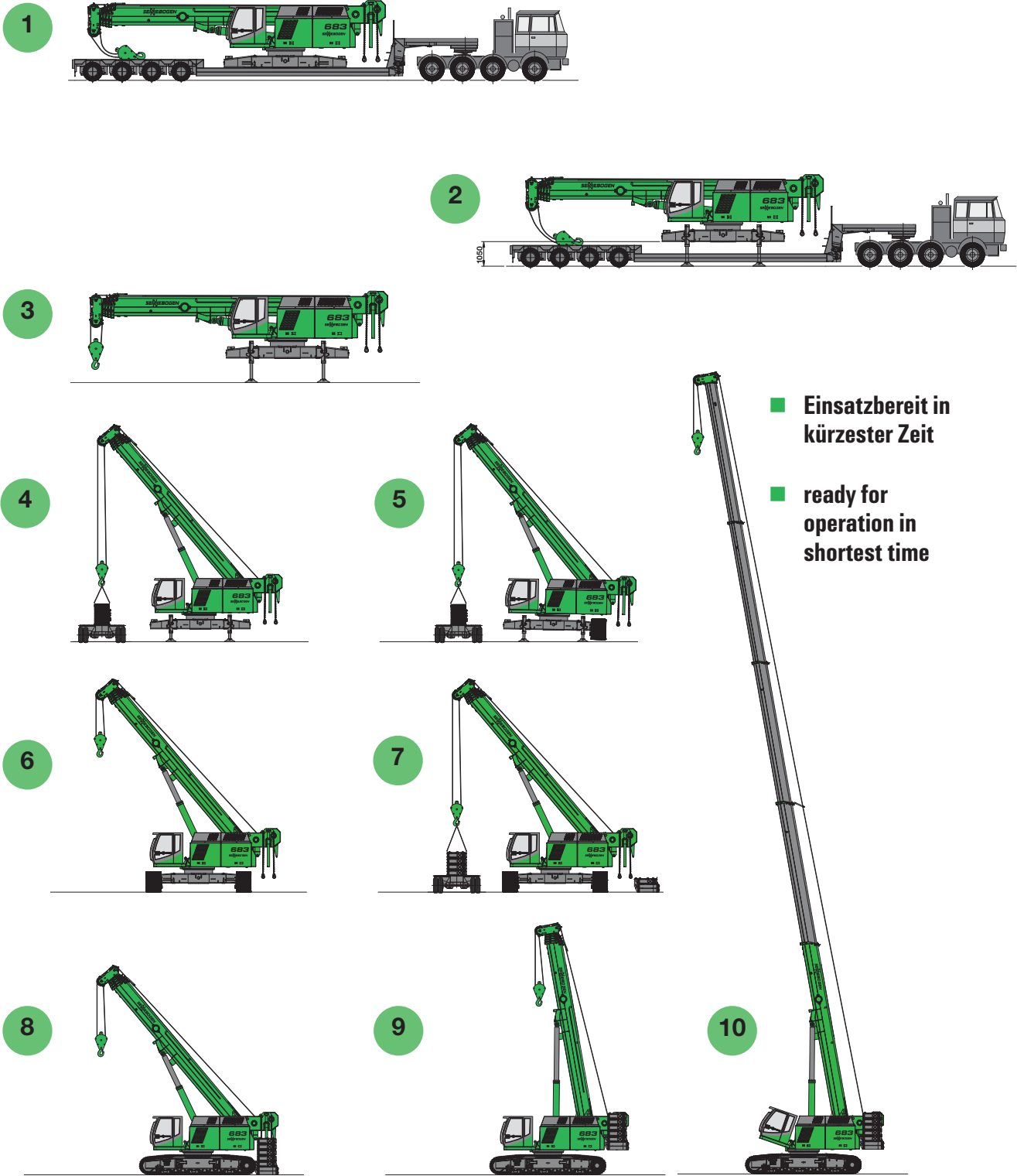

Neue Großraum-Komfortkabine mit Schiebetür

New king-sized comfort cabin with sliding door

MAX CAB

Luftgefederter Komfortsitz
mehrfach verstellbar mit Bandscheibenstütze und Sitzheizung, einstellbare Armlehnen

Air suspended comfort seat
adjustable with lumbar support and seat heating, adjustable armrests



Schiebetür
erleichtert sicheres und bequemes Ein- und Aussteigen

Sliding door
Simplified and safe access to the operator's cab



Beste Ergonomie
Sitz ergonomisch komplett individuell zu den Steuerhebeln und separat zu den Fußpedalen einstellbar

Best ergonomics
Ergonomic operator's seat, individually adjustable in height and angle for optimum working environment and operator's comfort

Trittrost
serienmäßig = Sicherheit beim Auf- und Abstieg

Step
Standard - safety in entering and exiting

Hydraulisch um 20° neigbare Kabine
mit getöntem Sicherheitsglas, hydraulisch gedämpft und schwingungsgedämpft gelagert

Hydraulically tiltable cab; 20°
with safety glass tinted, hydraulically damped, resiliently mounted



SENNEBOGEN Diagnostic-System
zur Überwachung aller wichtigen Maschinen- und Motorfunktionen

SENNEBOGEN Diagnostic system
for monitoring of all essential machine and engine functions



Heiz-Klimaautomatik
mit Temperaturregelung, 8 einstellbare Lüfterdüsen sorgen für wohlige Klima, starke Defrosterfunktion, Frischluft/ Umluftsteuerung mit Partikelfilter

Automatic regulation
of heating and air condition according to temperature setting, 8 adjustable air vents provide excellent defrosting, air/circulation function, particle filter for outside and circulation air

683_{HD}

SENNEBOGEN

SENNEBOGEN
Maschinenfabrik GmbH
Sennebogenstraße 10
94315 Straubing, Germany

Tel. +49 9421 540-144/146
Fax +49 9421 43 882
marketing@sennebogen.de

BestellNr. / Item No. 085225
683 HD - 030430 - 070530* - 110715* - 040820 - 090835* - 031025* - 051230*